

# Journal of Islamic Thought and Civilization (JITC)

Volume 6, Issue II, Fall 2016

ISSN: 2075-0943, eISSN: 2520-0313

Journal DOI: <https://doi.org/10.32350/jitc>

Issue DOI: <https://doi.org/10.32350/jitc.62.01>

Homepage: <https://www.umat.edu.pk/jitc/home.aspx>

Journal QR Code:



Article:

## Perception of House Design in Islam: Experiences from Saudi Arabia and Pakistan

Author(s):

Sana Malik  
Beenish Mujahid

Online Pub:

Fall 2016

Article DOI:

<https://doi.org/10.32350/jitc.62.04>

Article QR  
Code:



To cite this  
article:

Malik, Sana, and Beenish Mujahid. "Perception of house design in Islam: Experiences from Saudi Arabia and Pakistan." *Journal of Islamic Thought and Civilization* 6, no. 2 (2016): 53–76.

[Crossref](#)

Copyright  
Information

This article is open access and is distributed under the terms of Creative Commons Attribution – Share Alike 4.0 International License



A publication of the  
Department of Islamic Thought and Civilization  
School of Social Science and Humanities  
University of Management and Technology  
Lahore

### Indexing Partners





## PERCEPTION OF HOUSE DESIGN IN ISLAM: EXPERIENCES FROM SAUDI ARABIA AND PAKISTAN

**Sana Malik**

School of Architecture and Planning,  
University of Management and Technology, Lahore, Pakistan

**Beenish Mujahid**

School of Architecture and Planning,  
University of Management and Technology, Lahore, Pakistan

### Abstract

Islamic planning principles offer guidance for designing home spaces. Islam as a code of life provides view points for designing houses and human interaction within these dwellings. The teachings of *Sunnah* and *Shari'ah* help in creating righteous and healthy individual, community and ultimately creating a healthy society. All such grooming principles originate from a home, whereas the structure and design of a house is given a form by considering local context, and human needs and different phases of planning and designing. One can observe many distinguishing examples of customary architecture of Islamic houses, in different Muslim and Arab countries. The objective of this research is to study the assimilation of Islamic housing concepts in different cultural settings by analyzing the contemporary house designs in Saudi Arabia and Pakistan. The research methodology is based on literature review and typological analysis of house designs of similar dwelling type. The analysis has further divided into different sections of house planning and design in light of Islamic teachings and cultural backgrounds. The paper scrutinizes the presence of architectural expression of Islamic perspective which administrated the design concept of the Muslim houses in said countries. Furthermore, it highlights the unique Islamic characteristics of residential design to provide a complete picture of current housing pattern adopted by Muslims of different geographical context.

**Keywords:** perception, housing, housing designs, Islam, lifestyle, spaces

### 1. Introduction

Houses also known as villas are the purest representation of human life in form of architectural expression. Islamic teachings help in creating righteous individual, leading to healthy community and ultimately to a blissful society. All such principles of education and grooming originate from a home. Location and human needs are considered as prime factors for designing a house. The execution of designed house plan takes places through interpretation of these observations and concerns by giving it a structural form. The presence of built environment is major footprint of man survival and residential architecture constitutes the maximum proportion of it. There





are no direct instructions provided by Islam for house design and building, however Qur'ānic verses provide guidelines for human interaction and doing daily tasks related to house spaces. The principles of Islam promote sustainable approach and simplicity for designing residential spaces. The constraints in contemporary housing structures exist due to negligence of these Islamic principles. Therefore, such design limitations in Muslim countries need to be investigated deeply. The discussion is divided into three main sections, (1) Islamic perception of house design (2) house designing practice in different Muslim countries (3) detailed comparative analysis of house designs of Saudi Arabia and Pakistan. First half of the research is based on literature review of relevant journal articles and books. The rest of research was conducted by gathering data of Saudi Arabian and Pakistani house designs of comparable constructed areas. The selection of the case study is based on the percentage of Muslim population living in these two countries. Firstly, being the historic land of Prophet (SAW), Saudi Arabia enjoys the eternal Islamic value and holds majority Muslim Population. Also, due to existence of pilgrim sites such as Holy Kaa'ba and Masjid-e-Nabavi, it experiences the practice of Islam in its purest form in the current situation. Secondly, Pakistan is the second largest Muslim country after Indonesia with 97% Muslim believers out of whole population (Figure 1). In addition to this, both countries enjoy good political relations with each other. The critical review of house designs in these two countries would be interesting to observe the shared similarity in fundamental nature of geographical and cultural housing typologies is same i.e., detached family houses. The binding force behind this conceptual similarity is tradition of Islamic values practiced by its civilizations. Saudi Arabian house locates in regional context of Jeddah and the Pakistani house is in regional context of Lahore. Both cities are second largest of their home countries and counted as modern and urbanized cities.

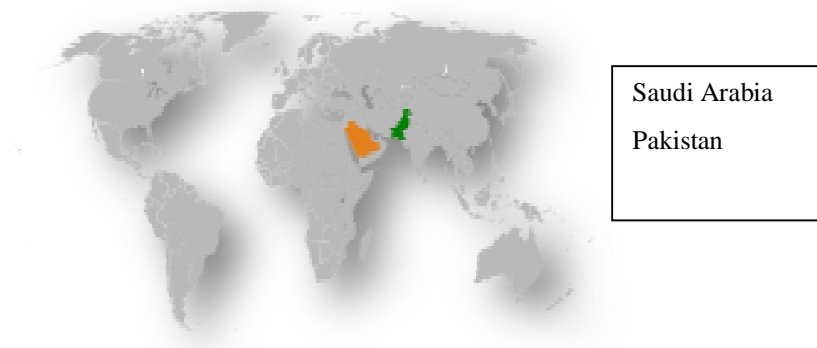

Figure1. Strategic location of Saudi Arabia and Pakistan<sup>1</sup>

<sup>1</sup>Strategic location of Saudi Arabia and Pakistan by Wikipedia.



The analysis has further divided into different sections of spatial planning and design in light of Islamic teachings and cultural backgrounds. The analytical study of Islamic perception and its incorporation into house design has been studied from Saudi Arabia and Pakistan. The objective of this paper is to scrutinize the presence of Islamic architectural expression which administrated the design concept of the Muslim houses in said countries. The paper highlights the unique characteristics of house design and the issues discussed in the lieu of it, providing a complete picture of current housing pattern adopted by Muslims of different cultures.

## 2. Islamic Perception of House Design

Islamic teachings including Qur'ān, *Sunnah*<sup>2</sup> and *Shari'ah*<sup>3</sup> affirm the strategic approach in every way of life. The Holy Qur'ān and life of Allah's Messenger (SAW) show that a Muslim should practice planning and management in all domains of activities i.e. social, economic or personal ones.<sup>4</sup> Qur'ān as literal word of Allah (SWT) and *Hadith* as divine sayings of last Prophet Muhammad (SAW) are regarded by Muslims all over the world. Ibrahim narrated that, "The Qur'ān, the central religious book of Islam, which Muslims consider the verbatim word of God (SWT), and the *Hadith*, regarded as a body of authoritative statements or acts from or about the Prophet Muhammad (SAW), both embody Islamic discourses about domestic space that emerged during the historical formation of the religion."<sup>5</sup> This promotes the culture of designing strategies in the house planning from all aspects. Such emphasis has evolved Islamic architecture as a complete code of design and constructions for all types of buildings, with house as its most prominent typology. Islamic dwelling was intended to facilitate the religious activities on daily basis. This complies that the layout of the house should complement the needs and requirements of its users. Afif Bahnami has quoted the saying of Ibn Qutuyba, a 9<sup>th</sup> century, renowned Muslim scholar that as the shirt should be best fit for its buyer (owner), similarly the house should suit for its inhabitants.<sup>6</sup> This further proves the suitability of house for its users in a more profound way. In Islamic architecture, forms and function formulate the aesthetic and functional framework respectively. The simple

---

<sup>2</sup>The Arabic word *sunnah* lexically means "road" or "practice." According to the Prophet (SAW) and the Companions's (RA) practices it denotes the whole of licit [lawful] practices followed in the Religion [*dīn*], particularly the pristine (*hanīf*) path of Prophets.

[http://www.sunnah.org/fiqh/usul/meaning\\_sunnah.htm](http://www.sunnah.org/fiqh/usul/meaning_sunnah.htm)

<sup>3</sup>*Shari'ah* is an Islamic religious law that governs not only religious rituals, but aspects of day-to-day life in Islam. *Shari'ah*, literally translated, means "the way."

<http://www.investopedia.com/terms/s/shariah.asp>

<sup>4</sup>Faysal Burhan and Michael D. Berdine, *Planning in Islam*, 2004.

<sup>5</sup>Hanna Ibrahim, "The Contemporary Islamic House," (Undergraduate Honors Thesis. Arkansas: University of Arkansas, 2012).

<sup>6</sup>Afif Bahnassi, *The Islamic Architecture and Its Specificities in Teaching Curricula*. ISESCO, 2003.





and functional approach towards creating a house design has given preference to function rather than form. Nevertheless, it does not mean that aesthetic sense is not practiced by its designers in Islamic houses. Importance has been given to architectural form on a secondary level as compared to function. Saphic Omer has suggested that there must be the closest relationship between the ideals that underpin the form of buildings and the ideals that underpin their function, with which the users of buildings must be at ease.<sup>7</sup> The built structures are associated with the context of its location and the life pattern of its users. Similarly, the buildings and structures located in an Islamic geographical context tend to figure the notion of Islamic architecture in the built environment. In this regard, a Muslim house is the most common category, where this contextual focus is satisfied by arranging inner spaces.<sup>8</sup>

Different religious concepts promote the designing tips for a house design including famous Indian and Chinese beliefs such as *Vastu Sashttra* and *Feng Shui* respectively. The mentioned beliefs are to provide guidance to its believers and the exposure of these beliefs is distracting the Muslims to follow the same pattern of house designing.<sup>9</sup> This is why; presently we see unnecessary decoration and expensive materials in most of contemporary house designs. Whereas, Muslims are prohibited to follow such concepts of home décor with emphasis on the material things and extra expenditure on dwelling spaces.<sup>10</sup> There is fundamental need to highlight the teachings of Qur'ān, collections of *Hadith* and Prophetic (*SAW*) actions as they provide a complete code of life one of the main reasons delivering an authentic proof of creation of this universe and early human existence. Qur'ānic teachings give information about the houses of Allah (*SWT*), his prophets (*AS*) and the believers, but they do not provide the complete handbook of designing a house. The driving strength of Islamic house designs is based on social/cultural context, geographical location and historical content. A house is considered as a heaven functioning both as a place for rest and private shelter to its users. Aman has emphasized that in Islam, house is a place to rest, relax body and mind, enjoy legitimate worldly delights, worship, teach, learn and propagate the message of Islam.<sup>11</sup> Few verses of Qur'ān features the terminology of Islamic house. In Qur'ān, Allah (*SWT*) has given clear depiction of human dwelling as follows:

<sup>7</sup>Saphic Omer, *Islam and Housing* (Malaysia: A.S. Noordeen, 2010)

<<http://www.islamicbookstore.com/b11514.html/>>.

<sup>8</sup>Linda N. Groat, and David Wang, *Architectural Research Methods*, 2nd Edition (New Jersey: John Wiley and Sons., 2013)

<sup>9</sup>Carla Jordan, "Guide to Feng Shui and Vastu Shastra," 16 April 2009, Accessed on 28 February 2017 <<http://www.elledecor.com/life-culture/cleaning-organizing/g142/feng-shui-vastu-shastra-sans-the-spiritual-stuff-55999/>>.

<sup>10</sup>Abdul Hamid Siddiqi, *Islamic Building Design: Beyond Calligraphy and Domes* (IBS Buku Sdn Bhd, 2010)

<sup>11</sup>Nur Uyun Bt. Aman, "Islamic Housing Design," 24 November 2010. Accessed on 30 January 2017. <<https://www.scribd.com/doc/43900451/Islamic-Housing-Design>>.



Allah (SWT) has made your homes the place for your rest, and animal skins for the true believers. Allah (SWT) has made your homes the place for your rest, and animal skins for tents as houses so that you may find them light when you travel and easy to pitch when you stop; while from their wool, fur, and hair, He provides you household items and articles of convenience for you prescribed term of life...Thus He completes his favor to you, so that you may become Muslims.<sup>12</sup>

Houses and domestic furnishings have deep significance than just a place for shelter in Islam, with basic purpose of submission to divine power i.e., obeying to Allah (SWT). Qur'ān portrays the image of house as materials of regulatory discourse. Such unconditional orders give guidance to do different activities associated with a house such as catering visitors/ guests, eating and living spaces, privacy, connection with neighbors and cleanliness in and out of the house. Extending hospitality and strengthening relationships with society have given priority to strength the community in Islamic house design. This feature is being practiced in the house of Prophet Muhammad (SAW) has of where large area of land was specified for social interaction for the purposes of listening issues and providing guidelines (Figure 2).

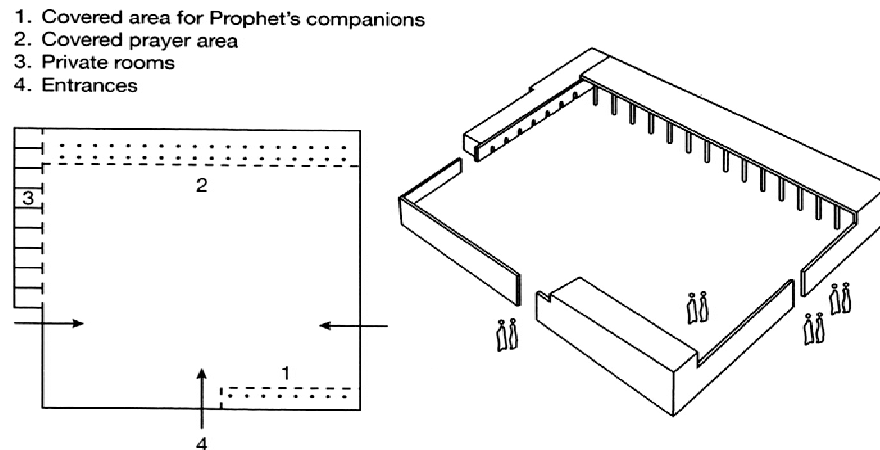

Figure 2. House of Prophet Muhammad (SAW)<sup>13</sup>

The *Hadith* literature provides further extensive collection of such statements with Islamic house content. Muslims follow the *Hadith* with full acceptance as these are the authentic sayings of Prophet (SAW) and their companions. Houses and spatial interactive behavior within are the objects of Islamic causal debates. The wisdom words by Prophet (SAW) further strengthen the concept of houses as places of

<sup>12</sup>Al-Qur'ān, Nahl 16: 79-81. English Translation of the Meaning of al-Qur'ān: *The Guidance for Mankind*. Translated by Muhammad Farooq-i-Azam Malik (Houston: The Institute of Islamic Knowledge, 1997)

<sup>13</sup>Zulkeplee Othmann, Rosemary Aird and Laurie Buys, "Privacy, Modesty, Hospitality and the Design of Muslim Homes: A Literature Review," *Frontiers of Architectural Research* (2015): 12-23.



worship and provide governing rules to have some control on domestic spaces. There is clear indication of providing a separate special place for mosque in an Islamic house. Muslims strongly believe that praying *Salah* in designated mosque will bring happiness and contentment in their lives. Prophet Muhammad (SAW) said, “the likeness of a house in which Allah (SWT) is remembered and the house in which Allah (SWT) is not remembered is that of the living and the dead, respectively.”<sup>14</sup> Another viewpoint discussed in *Hadith* is the care for the neighbors. In this regard, hadith contains the similar thought i.e., “He is not a believer whose stomach is filled while the neighbor to his side goes hungry.”<sup>15</sup> Same concern has also been mentioned in another *Hadith* where prophet Muhammad (SAW) stated that, “if you cook something with gravy, increase the gravy and send some of it to your neighbors.”<sup>16</sup> The privacy of neighbors is also meant to be respected according to Messengers of Allah (SAW). This concern of modern house was highlighted centuries ago in *Hadith* where Abu Hurairah (RA) conveyed the Prophet’s (SAW) saying as “he who peeped into the house of other people without their consent, it is permissible for them to put out his eyes.”<sup>17</sup> There are certain set of rules for placing WCs in toilets according to Islamic teachings. The facing of WC is not preferred to face *Qibla*<sup>18</sup> while defecating or urinating as mentioned in the *Hadith* “When any one of you goes to defecate, let him not face toward the *Qiblah*, rather let him face toward the east or the west.”<sup>19</sup> Relevant Etiquette of *Istinja*<sup>20</sup> is one the most important feature to be followed while designing the layout of Muslim Toilet spaces. In this regard, the position of water hose counts prominently as it is preferred to be on the right of the WCs so that water taps can be easily used with right hands and cleaning with left hands which is the Islamic way of cleaning private parts of body.<sup>21</sup> For the wash basin or the water tap, it is good to align it towards *Qibla* because it is *Sunnah* to face the *Qibla* while taking

<sup>14</sup>Muhammad Salih Al-Munajjid, *The Muslim Home - 40 Recommendations*, 2007.

<sup>15</sup>Al-Baihqī, *Sunan al-Kubrā*: 18099; *Sahih* (authentic) according to Al-Albani; 5382

<<http://dailyhadith.abuaminaelias.com/2012/08/12/hadith-on-neighbors-he-is-not-a-believer-whose-stomach-is-full-while-his-neighbor-is-hungry/>>

<sup>16</sup>Imam Hafiz Abu isa Mohammad Ibn Isa Tirmidhi, *Jami Tirmidhi*, 1833; English vol. 3; Book. 23, Hadith 1833. <<http://www.tib-e-nabi-for-you.com/meat.html>>.

<sup>17</sup>Muslim bin Hajjaj, *Sahih Muslim*, 5370: Book. 25, Hadith no.5370.

<[http://www.searchtruth.com/searchHadith.php?keyword=who+peeped+into+the+house+&translator=2&search=1&book=&start=0&records\\_display=10&search\\_word=all](http://www.searchtruth.com/searchHadith.php?keyword=who+peeped+into+the+house+&translator=2&search=1&book=&start=0&records_display=10&search_word=all)>

<sup>18</sup>The *Qibla* is the direction that should be faced when a Muslim prays during prayers (salah). It is fixed as the direction of the Kaaba in Makkah.

<sup>19</sup>Imam Ahmad an-Nasai, *Sunan An-Nasai*, Chapter No: 1, “The Book of Purification,” Hadith no: 22. <<http://ahadith.co.uk/hadithsearchfilter.php?id=16&q=defecate>>.

<sup>20</sup>*Istinja* is to clean Urine and Stool off private parts after urination and defecation.

<sup>21</sup>Nur Zalikha Mohd Aamer, Zulhabri Ismail and Hafez Salleh, “Guidelines for Internal Arrangement of Islamic House,” 2012 IEEE Business, Engineering & Industrial Applications Colloquium (BEIAC) (Kuala Lumpur: IEEE, 2012), 189-194.

ablution.<sup>22</sup> Ibrahim<sup>23</sup> (2012) has derived some of the basic design principles inspired by discussed Islamic teachings. A summary of these is given in the table below:

Table1. Islamic Principles for a House Design<sup>24</sup>

Design Feature	Graphical Presentation	Comments
Entrance	<p>bent entry:</p>	Bent entry to facilitate the private approach into the house
Inward Looking	<p>internal focus</p>	The orientation of residential spaces is focused inwards.
Minimal Design of Façade		Simple approach and minimum design features used on exterior to portray modesty.
Gender based Spatial organization		Privacy being one of the prime concerns in Islamic House promotes gender based spatial organization.
Sunken Courtyard		Central courtyard at a lower level is a climatic responsive architectural feature. Also, it provides

<sup>22</sup>Abdul Hamid Siddiqi, *Islamic Building Design: Beyond Calligraphy and Domes* (IBS Buku Sdn Bhd, 2010)

<sup>23</sup>Hanna Ibrahim, "The Contemporary Islamic House" (Undergraduate Honors Thesis. Arkansas: University of Arkansas, 2012).

<sup>24</sup>Ibid.





Iwan		<p>Iwan is old name of Modern day Verandah which serves as covered platform for enjoying beautiful views of courtyard.</p>
Masharabiya (Screen Patterns)		<p>Women have given equal opportunity to enjoy the natural views through Masharabiyas (screened patterns in wall) by maintaining their privacy.</p>
Placement of Toilet		<p>The alignment of toilet in a house is a delicate issue as it is not allowed to face the Qiblet while using WC.</p>

### 3. Housing Practices in Different Muslim Countries

Omer has considered house as microcosm of culture and civilization, because the primary elements because the primary elements of society, individuals organized along with the family lines, are born, raised and educated in them.<sup>25</sup> In the recent years, Muslims of different countries have established their own residential architecture. With the background of Islamic teachings, combined with local climatic conditions and construction techniques of varied nature have developed a typology of traditional houses in their home countries. House designs of few countries have been discussed as below.

#### 3.1. Syrian House

Syria and Iraq have history of initial findings of courtyard houses three ages go. The courtyard had got such an importance in realm of Islamic architecture that it has given the terminology of “architecture of the veil” due to its focus on inward looking plan and privacy of inner spaces.<sup>26</sup> Following debated design principles are summarized from the article of Alabidin who was the chairman of Shadirwan Center for Architectural Heritage in Syria.

<sup>25</sup>Spahic Omer, *Islam and Housing*.

<sup>26</sup>Mahmoud Zein Alabidin, *The Courtyard Houses of Syria, Muslim Heritage*, 10. Accessed on February 2017. <[http://www.muslimheritage.com/article/courtyard-houses-syria#\\_Toc240280843](http://www.muslimheritage.com/article/courtyard-houses-syria#_Toc240280843)>.



### 3.1.1 *Spatial Plan*

Three main divisions have been observed in traditional Syrian House which includes basement floor, a ground floor including the main living areas called *Al Salamlek*; and upper floor including the reserved/private spaces called *al Haramlek*.

### 3.1.2. *Courtyard*

In hot dry climates, courtyard is placed in the center of house plan to avoid extreme dry summer season and to provide shaded spaces with passage of airflow (Figure 3).



Figure 3. Traditional courtyard in a Syrian House<sup>21</sup>Source: (Alabidin n.d.)

### 3.1.3. *Iwan/Shaped Open Space*

*Iwan* is an Islamic design feature in a house design. It is located on the north side of the courtyard. An open u-shaped space articulated from three sides with its fourth side opens to the central courtyard to enjoy the beautiful views of landscape and natural environment. (Figure 4).



Figure 4. Iwan in a Traditional courtyard of Syrian House<sup>21</sup>

### 3.1.4. *Mushrabiya/Screen Patterns*

As discussed earlier in table 1, mushrabiya is a screen pattern provided on the outer elevation of house. It is of prime importance in Islamic sense as women can enjoy natural setting without losing their privacy. In case of Syrian houses, these





A traditional house in Malaysia has stairs at the entry point. The elevated space acts as a reception area and also a transitional space before the formal spaces of house interior. *Anjungen* compasses the privacy factor as an important Islamic feature in a house design, because it serves as meeting point for acquaintances and unfamiliar guests. Otherwise, it acts as community center for the inhabitants to socialize with their neighbors of the village. Again this component of Malay house encourages neighborhood which is one component of the Islamic sayings. From *anjung*, one enters into *Serambi Gantang* for which serves as entertainment area for family guests. This is a raised level from *anjung* with Windows at lower level for good ventilation.

### 3.2.2. *Rumah Ibu/Core House*

The next space after *serambi gantang* is the core house called *rumahibu*. This is further elevated level with maximum floor area, for carrying out major daily activities including sleeping, praying, studying and even feasting during family occasions and religious events.

### 3.2.3. *Selang/Transition Space*

This is connecting space between *rumahibu* and kitchen. This second transitional space after *anjung*, provides good socializing space for women and enhanced air flow inside house.

### 3.2.4. *Dapur/Back Space*

The last part of the house situated at back is the kitchen called *dapur* and has the lowest floor level in house. The space is purely dedicated to female occupants of house for preparing and cooking food, washing and eating. In addition to this, it also serves as place for group chatting.

## 3.3. Iranian House

Geometric pattern has been followed in spatial planning of Traditional houses in Iran featuring central courtyard with rooms arranged around it. Mir Moghtadaee has discussed important elements of an Iranian house which are summarized as below:<sup>29</sup>

### 3.3.1. *Family Size*

Iranian house is driven by household size; which is found to be an average of 6.5 birth rate for single woman. This implies that a traditional urban house belongs to a married couple with six or seven children, getting married and then staying close to the family. It is obvious that the house should be able to perform according to varying requirements of quickly increasing family size.

---

<sup>29</sup>Mahta Mirmoghtadaee, "Process of Housing Transformation in Iran," *Journal of Construction in Developing Countries* (2009): 69-80.





### 3.3.2. *Physical Features*

Cultural, local and contextual demands form up the spatial characteristics of a traditional house in Iran. In this regard, climatic responsive design of houses is more appreciated in different regions of country. Iran being hot and arid climatic territory, displays spatial designs of traditional values providing solutions to climatic demands. Like other discussed Muslim Houses, the introverted approach has applied to Iranian house designs.

### 3.3.3. *Courtyard*

Like many other Islamic countries, traditional houses in Iran contain courtyard as important design feature. Arrangement of rooms around the courtyard ensures that summer rooms will always be north facing and opposite side is featured with winter rooms. Architecturally, rooms are recognized by different design features such as morphology, location, number of openings, duration of usage and nature of function.

### 3.3.4. *Iwan*

*Iwan* is also an important design feature located within the courtyard for defining open and enclosed spaces (Figure. 6). Here, *iwan* is part of central courtyard and not just used in residential buildings but also public buildings. For relevant happenings in different seasons, the similar space provided in lower and upper ground floors also serves the same purpose of usage. Like Syrian house, Iranian house also features *iwan* as an integral part of courtyard.



Figure 6. Iwan of Traditional courtyard of Syrian House<sup>30</sup>

<sup>30</sup>Mahta Mirmoghtadaee, "Process of Housing Transformation in Iran," *Journal of Construction in Developing Countries* (2009): 69-80.



### 3.4. Kuwaiti House

The concept of traditional house in Kuwait was earlier perceived in early times dominated by Islamic regulations and traditions. Alhazim, et al. have discussed the philosophy of traditional Kuwaiti house. A review of discussed planning and design features has been given in the following table<sup>31</sup>:

Table 2: Design Features of Traditional Kuwaiti House<sup>32</sup>

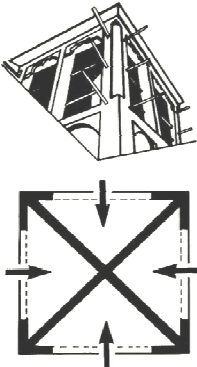
Design Features	Image	Description
1. Simple Design	-	Simplistic Approach of design, best suited with local climate.
2. Internal spatial organization	-	The articulation and organization of inner spaces was reliant on Financial and social standing, following abstract pattern of geometrical shapes.
2. Courtyard		Inner courtyard depicts the Islamic perception of modesty and introversion for domestic spaces. Privacy was maintained inside the courtyard through high walls.
3. Wind towers		This tall feature of traditional Kuwaiti House was located on rooftop with maximum height of 15 meters. Made of mud bricks, the purpose was to soften the impact of blazing warmth of desert by drawing out warmer air and letting in cooler air.

<sup>31</sup>Mohammad Alhazim, et al. "Design Philosophy of the Traditional Kuwaiti House," *Sustainability in Energy and Buildings: Research Advances*. Special Edition - Mediterranean Green Energy Forum 2013 (MGEF-13) : Vol.2 30 September (2012): 23-30.

<sup>32</sup>Ibid.



#### 4. Comparative Analysis of House Designs (Saudi Arabia and Pakistan)

The analysis of spatial planning and designing in houses of Saudi Arabia and Pakistan has been conducted thoroughly through photographic surveys and architectural drawings. The selection of houses in both countries is based on the following parameters:

1. Houses are occupied by Muslims family.
2. Architectural design is based on Islamic principle of privacy.
3. Both houses are examples of traditional architectural style of their respective country.
4. Families are living in joint setup.
5. The climate of selected case studies is warm for more than half year.

Different themes derived out based on the observations and documentation have been discussed in detail as below:

##### 4.1. Building Bye-Laws

Legal tools that provide building construction laws for cities are known as bylaws. These guidelines provide regulations for covered areas, building heights and architectural design and construction. These bye-Laws play an important role for systematic development of a region. These bye-Laws vary from area to area and place to place. The selected case studies have different byelaws as one is located in Defence Housing Authority, (DHA), Lahore, Pakistan and other is located in Hira Street, Jeddah, Saudi Arabia. Their guidelines vary due to their cultural setup. One of the most important features of house is its boundary wall. It gives an impression of privacy and closure when it is heightened and when its height become low it comes in concept of disclosure. The details of selected case studies are shown in table.

Table 3. Height of Boundary Wall in DHA Lahore Pakistan and Hira Street, Jeddah, Saudi Arabia

Location of Selected Case Study	Height of Boundary Wall	Impression	Image
DHA, Lahore, Pakistan.	6 ft – 8 ft (1.83-2.43)	Disclosure Exposed	



Hira Street, Jeddah, Saudi Arabia	9.84 ft (3m) Figure	Privacy Secrecy	
---	---------------------------	--------------------	--

### 4.2. Spatial Planning

Spatial Planning has a direct impact on the lifestyle of the building user. Islamic teaching does not provide any direct guiding principle for the placement of the different spaces but explain us how to perform different tasks, on the basis of which, guideline for spatial planning can be drawn out. True Muslim pays a lot of attention to the spatial planning according to Islamic rules for better living as remembrance of Allah (SWT) through praying five times a day is highly appreciated in Islamic religion. The house planning is divided into three major zones according to the privacy requirement including public zone, semi-public zone and private zone. (Figure 7)

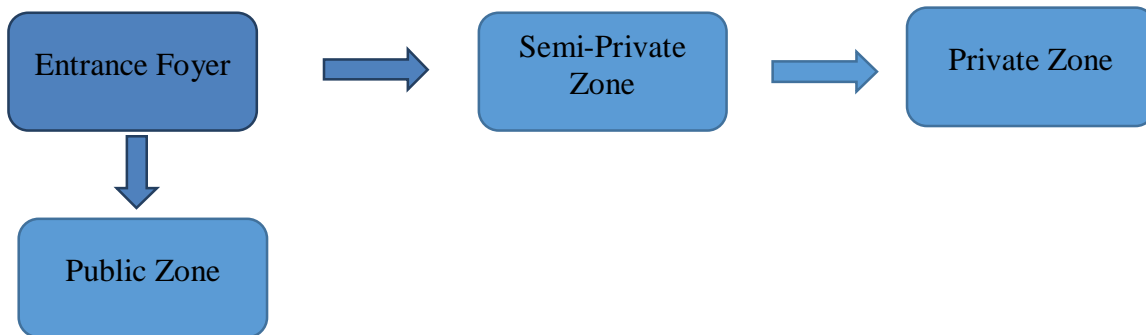

Figure 7. Arrangement of zones in a Typical Muslim House

The organization of house spaces varies from region to region and culture to culture. The typical spaces that are required in a house include car porch, entrance foyer, living room, prayer room, drawing – dinning, kitchen, bedrooms, guest bedroom and washrooms. Spatial planning of houses in both countries have been divided into three zones naming public zone, semi private zone and private zone (Figures 8 and 8). Figure 8 shows that ground floor of Saudi Arabian House is majorly dominated by public area with some portion of semi-private area. While the first floor is purely reserved for female users and titled as private zone. These zones help the family members to perform different tasks comfortably according to the Islam. On the other hand, Pakistani house has mixture of all the three defined zones on the ground floor and the same pattern is repeated on the first floor as well (Figure 9).





(a)

Figure 8 (a) Ground floor plan



(b)

(b) First floor Plan of house located in Hira Street, Jeddah, Saudi Arabia



(a)

Figure 9. (a) Ground floor plan

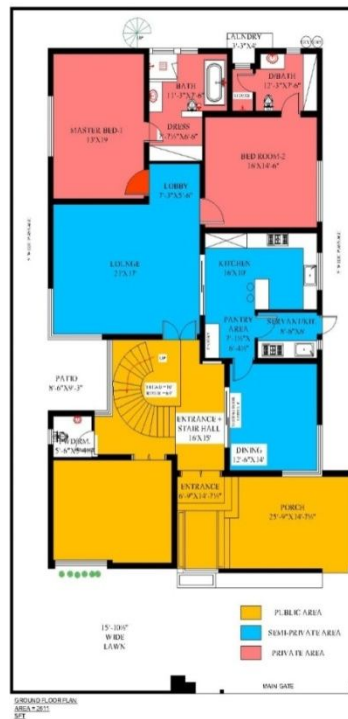

(b)

(b) First floor Plan of house located in DHA, Lahore, Pakistan



### 4.3. Entrance Foyer

Islamic religion strictly enforces segregation of non-mehram male from female members to maintain privacy. Therefore, it is advisable to provide separate doors for private and public zones. This tradition is adopted in almost all the Muslim countries and separate doors are provided in the main entrance lobby for public space i.e. drawing room; semi-private i.e., living room and kitchen public spaces and private spaces i.e., bedrooms as shown in figure. Provision of staircase and guest toilet is also given in main entrance area (Figure 10).



(a)



(b)

Figure 10. (a) Views of Entrance Foyer showing opening to public zone and semi-private zone (a) DHA, Lahore, Pakistan (b) Hira Street, Jeddah, Saudia Arabia

### 4.4. Drawing Rooms

In Islamic countries, privacy is one of the most basic requirements that have been incorporated in the design of every house. Privacy gives comfort and safety to the dwellers. Privacy can be maintained in three different ways which include visual privacy, acoustical privacy and olfactory privacy. In both selected case studies, Drawing room is especially reserved for non-mehram<sup>33</sup> guest to serve the purpose of hosting (Figure 10). It is placed at an isolated space within a Muslim house so that the women can perform their tasks within a house.

<sup>33</sup>*Non-Mehram*: The Arabic term mehram is derived from haraam which literally means something which is sacred, or sacrosanct, or prohibited. In the terminology of Islamic Jurisprudence a mehram relative is generally one to whom marriage is absolutely and permanently prohibited; and a non-mehram is generally one to whom marriage is permissible.



(b)



(a)

Figure 11. (a) Views of drawing room showing furniture arrangement (a) DHA, Lahore, Pakistan (b) Hira Street, Jeddah, Saudia Arabia

#### 4.5. Bedrooms

The main compartment of the house is bedroom. The reason behind is that people usually spend more than eight hours of daily life inside these private spaces for sleeping, studying, grooming, and praying. Islamic teaching doesn't give us any guidelines regarding the interior design of bedroom. But there are some social and ethical guidelines that can lead to better design of bedrooms. Islam religion gives guideline for the placement of bed in a Muslim house. It should be facing *Qiblah* i.e. 260.527164 Clockwise from True North in Pakistan. (Figure 12)



Figure12. Interior of Bedroom showing placement of bed in DHA, Lahore, Pakistan

In Saudia Arabia, sleeping accommodation for family is sometimes provided on first floor for the convenience of the female occupant who have to veil their faces when guests come. Another important consideration that should be considered during bedroom design is placement of door. Door should be inward and the location of bed is not visible from the door to provide privacy among family members (Figure 13).



Figure 13. Design of bedroom space in Saudi Arabian House

#### 4.6. Washrooms

Washroom design plays a very important role in Islamic Architectures as certain values are related to its placement. Muslims faces *Qibla* during prayer, this means that toilet/ WC should not be placed on that direction. (Figure 14)

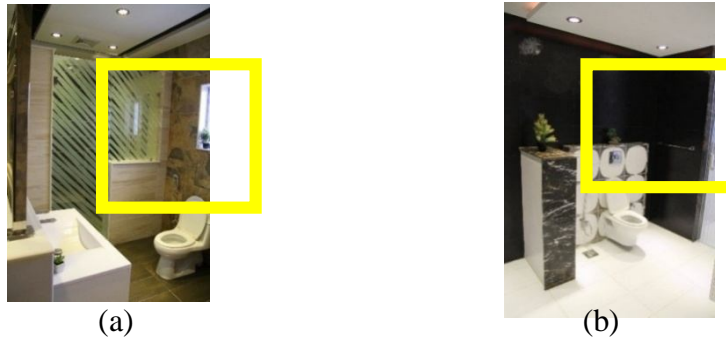

Figure14. (a) Interior view of washroom (b) Placement of washrooms with reference to *Qibla* Direction

#### 4.7. Terraced Courtyard

Terraced courtyard is a distinguished feature in house planning of Pakistan. It is provided in some of the contemporary houses to facilitate the female users of the house to enjoy the outdoor environment without sacrificing their privacy. In the particular case, the courtyard is provided next to the lounge area on the first floor and wall with punctures is provided instead of giving the handrail (figure 15).



(a)

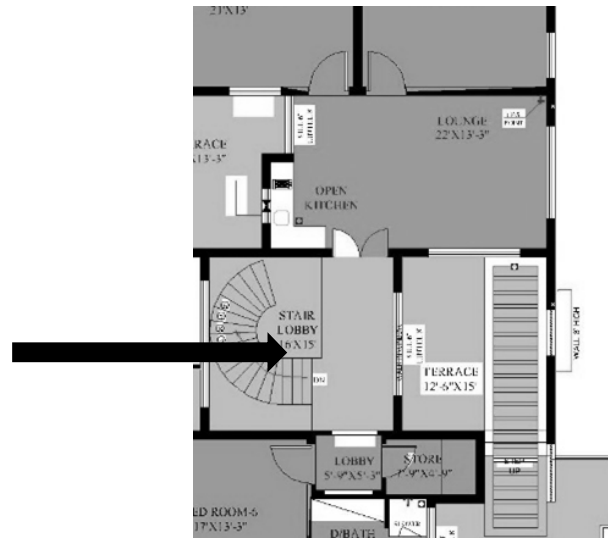

(b)

Figure15. (a) View of terraced courtyard (b) location of terraced courtyard on first floor plan

#### 4.8. Window Placement

Islamic traditions do not allow Muslims to violate visual privacy by looking into neighbor houses through windows. For this purpose special consideration is given to the design of windows. In traditional houses of Saudi Arab, small window have been provided as shown in figure to provide privacy to the users (Figure 16). On the contrary, window openings in courtyard have been provided in traditional houses of Lahore.

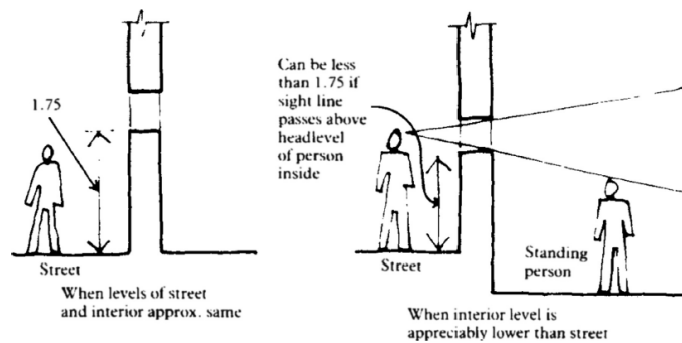

Figure 16. Window placement

Source: (Othmann, Aird and Buys 2015)

But in modern houses, this tradition is not adopted and visual privacy is maintained with the help of curtains (Figure 17).



Figure 17. Modern way of maintaining privacy through curtains in rooms

## 5. Conclusion

House reflects cultural trends and it is built according to man's understanding of the world. This study shows that how Muslims of different countries built houses according to their requirements and culture. There is a lack of Islamic housing concept due to little awareness about the Islamic knowledge among the present Muslim generation which has resulted in western direction of house design. The research has highlighted the dedicated significance of dwelling spaces and its layout in Islam. In addition to this, the study has tried to make a contribution to increase the perception of Muslims about the Islamic House design according to the wish of their Creator, Allah (SWT) (SWT). Comparative analysis shows that the general trend of Housing in Pakistan is moving towards Modernism. However, the concept of *mushrabiya* has made its extension in form of terraced courtyard maintaining the privacy for female users in modern Pakistani House. The old concept of traditional "BAITHAK," Male drawing room has gone in case of Pakistani house and has been replaced with modern drawing room in which male and female guests sits together. Whereas, this tradition is still followed in Arabic Countries where Male drawing rooms are provided separately like in case of Saudi Arabia. Also, shows that avoiding the mix-gender environments is facilitated through reserving the first floor for women only. A summary of comparative analysis of both case studies is given in following table:



Table 5. Summary of Comparative Spatial Planning in Pakistani and Saudi Arabian House

Pakistani House	Distinctive Features	Saudi Arabia House
1	Female family members are accommodated on ground and first floor also.	First floor is reserved for female family members.
2	Public area i.e., drawing room is connected with semi-public area.	Public area is kept separated from semi-public and private areas.
3	Non-hierarchical design of privacy zones.	Hierarchical design of privacy zones.
4	Having guest room in semi-public zone.	Having guest room in public zone.
5	Have dining room in semi-public layer.	Have dining room in public layer.
6	Have one staircase for family and guest.	Have two staircases.

#### Common Features

- Both houses have single entrance foyer for public, semi-public and private zones.
- Both house received sunlight through outside. Concept of courtyard is not given in design phase

The summary implies that the Islamic pattern of living is witnessed in more practical form in comparison to a Pakistani house. To build Muslim housing community in Pakistan, different private and public stakeholders involved in housing industry should take appropriate initiatives for the formulation of Islamic house design principles. Such principles of house design provide a complete manual of satisfying the concepts of privacy and comfort in a house with more focus on sustainable living.

#### BIBLIOGRAPHY

- Aamer, Nur Zalikha Mohd, Zulhabri Ismail and Hafez Salleh. "Guidelines for Internal Arrangement of Islamic House." 2012 IEEE Business, Engineering and Industrial Applications Colloquium (BEIAC). Kuala Lumpur: IEEE, 2012. 189-194.
- Alabidin, Mahmoud Zein. "The Courtyard Houses of Syria." *Muslim Heritage*. n.d. 10 february 2017. <[http://www.muslimheritage.com/article/courtyard-houses-syria#\\_Toc240280843](http://www.muslimheritage.com/article/courtyard-houses-syria#_Toc240280843)>.



- Alhazim, Mohammad, et al. "Design Philosophy of the Traditional Kuwaiti House." *Sustainability in Energy and Buildings: Research Advances*. Special Edition - Mediterranean Green Energy Forum 2013 (MGEF-13) : Vol. 2, 30 September 2012: 23-30.
- Aman, Nur Uyun Bt. "Islamic Housing Design." 24 November 2010. Scribd. 30 January 2017. <<https://www.scribd.com/doc/43900451/Islamic-Housing-Design>>.
- Amar, Nur Zalikha Mohd, Zulhabri Ismail and Hafez Salleh. "Guidelines for Internal Arrangement of Islamic House." 2012 IEEE Business, Engineering and Industrial Applications Colloquium (BEIAC). Kuala Lumpur: IEEE, 2012. 189-194.
- Bahnassi, Afif. *The Islamic Architecture and its Specificities in Teaching Curricula*. ISESCO, 2003.
- Burhan, Faysal and Michael D. Berdine. *Planning in Islam*. 2004.
- Farooq-i-Azam, Muhammad. *English Translation of the Meaning of al-Qur'ān: The Guidance for Mankind*. Houston: The Institute of Islamic Knowledge, 1997.
- Groat, Linda N. and David Wang. *Architectural Research Methods*. 2nd Edition. New Jersey: John Wiley and Sons, 2013.
- GSSD - Global South-South Development Academy. "Examples of Good Practices in Social Policies, Indigenous and Traditional Knowledge, and Appropriate Technology in the South." volume 4 of the Series *Sharing Innovative Experiences*. n.d.
- Ibrahim, Hanna. "The Contemporary Islamic House." Undergraduate Honors Theses. Arkansas: University of Arkansas, 2012.
- Jordan, Carla. Guide to Feng Shui and Vastu Shastra. 16 April 2009. 28 February 2017. <<http://www.elledecor.com/life-culture/cleaning-organizing/g142/feng-shui-vastu-shastra-sans-the-spiritual-stuff-55999/>>.
- Mirmoghtadaee, Mahta. "Process of Housing Transformation in Iran." *Journal of Construction in Developing Countries* (2009): 69-80.
- Munajjid, Muhammad Salih. *The Muslim Home - 40 Recommendations*. 2007.
- Omer, Spahic. *Islam and Housing*. Malaysia: A.S. Noordeen, 2010.
- . "Islamic Architecture and the Prospects of its Revival." *Journal of Islamic Thought and Civilization* (2011): 115-136.
- Othmann, Zulkeplee, Rosemary Aird and Laurie Buys. "Privacy, Modesty, Hospitality, and the Design of Muslim Homes: A Literature Review." *Frontiers of Architectural Research* (2015): 12-23.





Sani, Norazmawati Md. "Modern Houses Design for Malaysian." *Advances in Applied Science Research* (2012): 3810-3813.

Siddiqi, Abdul Hamid. *Islamic Building Design: Beyond Calligraphy and Domes*. IBS Buku Sdn Bhd, 2010.